

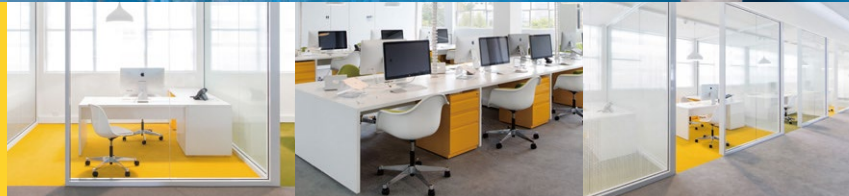

RhinoEU®

Calcium Sulphate Panel



EU 800/1000/1250/1500 Bare Finish Panel

RhinoEU® Bare finish panels are manufactured from a high density of calcium sulphate (approx. 1,650 kg/m³) non-toxic and non-combustible material. The top and base surfaces of the core are laminated with galvanized steel sheet. The panel edges are then laminated with an ABS/PVC edge band which provides protection to the calcium sulphate core.

RHINO®
Strive for perfection!

Technical Data Sheet

RhinoEU® Bare

Panel

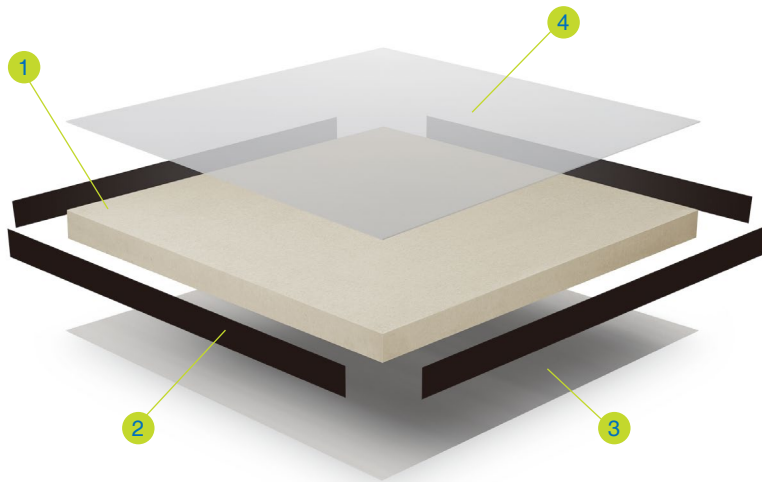

1 Calcium Sulphate Core

Thickness: 30/34/38mm
Material: Calcium sulphate
(approx. 1,650kg/m³)

2 Edge Band

Thickness: 0.5mm
Material: Conductive PVC/ABS

3 Under Layer

Thickness: 0.3/0.4/0.5/0.6mm
Material: Galvanized steel sheet

4 Top Layer

Thickness: 0.3/0.4/0.5/0.6mm
Material: Galvanized steel sheet

Description

RhinoEU® Bare finish panels are manufactured from a high density of calcium sulphate (approx. 1,650 kg/m³) non-toxic and non-combustible material. The top and base surfaces of the core are laminated with galvanized steel sheet. The panel edges are then laminated with an ABS/PVC edge band which provides protection to the calcium sulphate core.

Features

- Non-toxic
- Non-combustible
- Impressive acoustic performance
- Superb underfoot comfort
- High load capacity
- Low air leakage rate

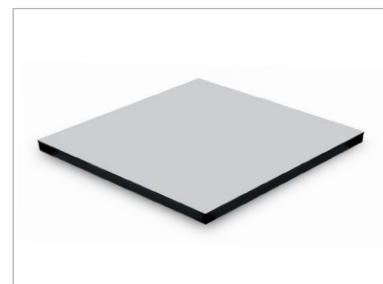
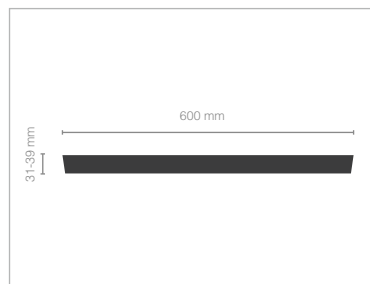

Panel Type	Panel Size	Core Material	Panel Construction	Panel Thickness (Nominal)	System Weight (Typical)
EU 800	600mm square	Calcium Sulphate	Galvanized steel sheet top & bottom with edge band	31.00 mm	56.00 Kg/m ²
EU 1000	600mm square	Calcium Sulphate	Galvanized steel sheet top & bottom with edge band	31.00 mm	58.00 Kg/m ²
EU 1250	600mm square	Calcium Sulphate	Galvanized steel sheet top & bottom with edge band	35.00 mm	62.00 Kg/m ²
EU 1500	600mm square	Calcium Sulphate	Galvanized steel sheet top & bottom with edge band	39.00 mm	68.00 Kg/m ²

Technical Data Sheet

RhinoEU® Bare

System

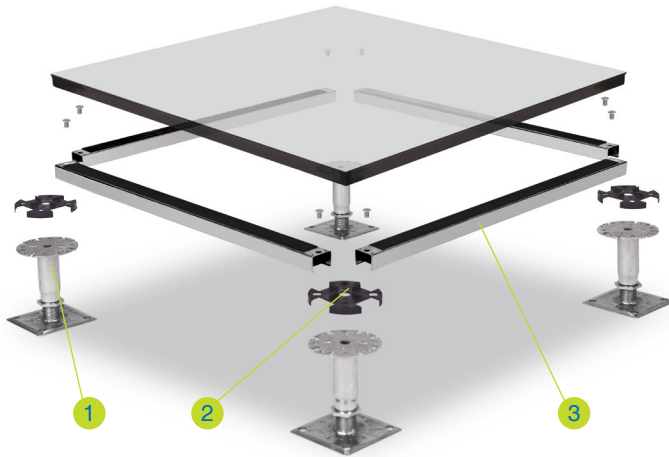

1 Standard Pedestal

Electro-galvanized steel made pedestal is suitable for raised floors with a finished floor height from 100mm to 1800mm. Zinc whisker free is available for special order.
Material: Steel, Yellow Galvanized.

2 Head Gasket

Plastic conductive material with sound proofing and sealing functions, equipped with tabs for the positioning of panels.
Thickness: 2.0mm

3 Stringer

Steel tube performed stringer with plastic gasket on top provide best supports to the structural system with limited air leakage and outstanding acoustic performance.
Dimension: 537mm x 30mm x 20mm
Thickness: 0.8/1.0/1.2mm

Pedestal

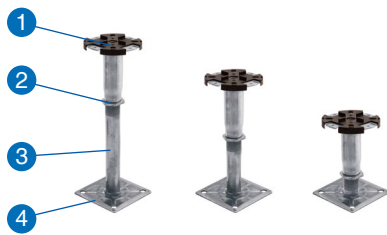

1 Head Assembly

Head plate: Ø90mm x 3.0mm
Head tube: Ø32mm x 2.0mm

2 Adjusting Nut

M24 with vibration proofing locking device

3 Base Tube

Ø25mm x 2.5mm

4 Base Plate

□100mm x 2.5mm

Performance

- This rigid grid system is tested in accordance with PSA MOB PS/SPU specification.
- Panel deflection at centre edge must not exceed 2.5mm
- Performance to a safety factor of 3 x static load
- Structural performance based upon a full Rhino access floors system i.e. panels & pedestals.



Panel Type	Panel Grade	Concentrated Load		Uniformly Distribution Load	Ultimate Load (Safety Factor 3.0)
		Point Load	Load Over		
		25mm x 25mm square	300mm x 300mm square		
EU 800	Medium Duty	3.00 kN	4.50 kN	8.00 kN/m²	9.00 kN
EU 1000	Heavy Duty	4.50 kN	5.56 kN	12.00 kN/m²	13.50 kN
EU 1250	Extra Heavy Duty	5.56 kN	6.67 kN	16.00 kN/m²	16.68 kN
EU 1500	Super Heavy Duty	6.67 kN	8.90 kN	20.00 kN/m²	20.01 kN

RHINO[®]

Strive for perfection!

Corporate Headquarters

111 S.K.V. Building, 4th Floor
Soi Sansabai, Klongton
Klongtoey, Bangkok 10110
Thailand

T/ (662) 661 2990

F/ (662) 661 2991

China Office

593, Tongjiang Road
Jintian Plaza 828-830
Changzhou 213022
Jiangsu, China

T/ (86) 519 8988 3171

F/ (86) 519 8988 3901

Hong Kong Office

Unit 908, 9/F, LT Tower
31 Chong Yip Street
Kwun Tong, Kowloon
Hong Kong

T/ (852) 2865 6816

F/ (852) 2865 6813

Production Unit

Hengshanqiao
Wujin District
Changzhou 213119
Jiangsu, China

T/ (86) 519 8860 7959

F/ (86) 519 8860 5659

www.RhinoAccessFloors.com